

## "PV2R" Series Double Vane Pumps

These double pumps consist of two PV2R series single pumps combined in tandem within a single housing and driven by a common shaft. A single suction port and two discharge ports are provided so that the output flow can be supplied to separate circuits.

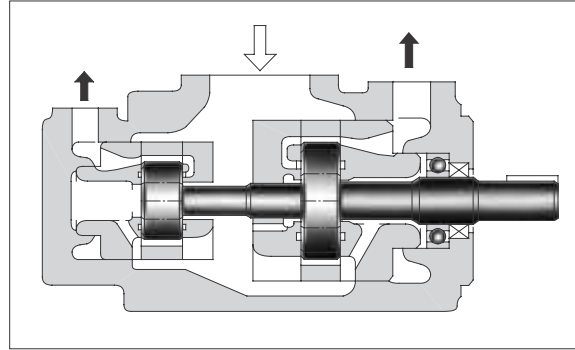

Graphic Symbol

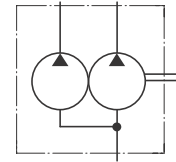

B



"PV2R" Series Double Vane Pumps

### Model Number Designation

| F-  | PV2R13        | -6   | -76  | -L                     | -R                                     | A   | A   | A                     | -40           | *                      |
|---|---------------|--|--|------------------------|--|---|---|-----------------------|---------------|------------------------|
| Special Seals   | Series Number | Small Volume Pump Nominal Displacement<br>cm <sup>3</sup> /rev | Large Volume Pump Nominal Displacement<br>cm <sup>3</sup> /rev | Mounting               | Direction of Rotation                  | Small Volume Pump Discharge Port Position | Large Volume Pump Discharge Port Position | Suction Port Position | Design Number | Design Standards       |
| <b>F:</b><br>Special seals for phosphate ester type fluids (Omit if not required) | PV2R12        | 6, 8<br>10, 12<br>14, 17<br>19, 23<br>25, 31                   | 26, 33<br>41, 47<br>53, 59<br>65                               | L:<br>Foot Mtg.        | R: <sup>★1</sup><br>Clockwise (Normal) | (Viewed from Shaft End)                   |   | A                     | 42            | Refer to <sup>★2</sup> |
|   | PV2R13        | 6, 8<br>10, 12<br>14, 17<br>19, 23<br>25, 31                   | 76, 94<br>116  |                        |  | A:<br>Upwards (Normal)                    | A:<br>Upwards (Normal)                    |                       |               |                        |
|   | PV2R23        | 41, 47<br>53, 59<br>65   | 52, 60<br>66, 76<br>94, 116                                    |                        |  | E:<br>Left 45°<br>Upwards (Normal)        | A:<br>Upwards (Normal)                    |                       |               |                        |
|   | PV2R33        | 76, 94<br>116  | 76, 94<br>116  | F:<br>Flange Mtg.      |  | A:<br>Upwards (Normal)                    | A:<br>Upwards (Normal)                    |                       |               |                        |
|   | PV2R14        | 6, 8<br>10, 12<br>14, 17<br>19, 23                             | 136, 153<br>184, 200<br>237                                    | A:<br>Upwards (Normal) |  | A:<br>Upwards (Normal)                    |   |                       |               |                        |
|   | PV2R24        | 26, 33<br>41, 47   |  | A:<br>Upwards (Normal) |  | A:<br>Upwards (Normal)                    |   |                       |               |                        |
|   | PV2R34        | 52, 60<br>66, 76<br>94, 116                                    | E:<br>Left 45°<br>Upwards (Normal)                             | A:<br>Upwards (Normal) |  |   |   |                       |               |                        |

★1. Available to supply pump with anti-clockwise rotation. Consult Yuken for details.

★2. Design Standards: None ..... Japanese Standard "JIS" and European Design Standard 90 ..... N. American Design Standard

**Specifications**

**Maximum Operating Pressure**

| Nominal Displacement<br>cm <sup>3</sup> /rev | Max. Operating Pressure MPa (PSI) |              |  |               |                        |                  |
|--|-----------------------------------|--------------|--|---------------|------------------------|------------------|
|  | Petroleum Base Oils               |              | Water Containing Fluids                    |               |                        | Synthetic Fluids |
|  | Anti-Wear Type                    | R & O Type   | Anti-Wear Type Water Glycols <sup>★1</sup> | Water Glycols | Water in Oil Emulsions | Phosphate Esters |
| 6  | 21 <sup>★2</sup><br>(3050)        | 16<br>(2320) | 16<br>(2320)                               | 7<br>(1020)   | 7<br>(1020)            | 16<br>(2320)     |
| 8  |                                   |              |  |               |                        |                  |
| 10   |                                   |              |  |               |                        |                  |
| 12   |                                   |              |  |               |                        |                  |
| 14   |                                   |              |  |               |                        |                  |
| 17   |                                   |              |  |               |                        |                  |
| 19   |                                   |              |  |               |                        |                  |
| 23 <sup>★3</sup>                             | 21 <sup>★3</sup><br>(3050)        |              |  |               |                        |                  |
| 25   | 21<br>(3050)                      |              |  |               |                        |                  |
| 31   | 16<br>(2320)                      |              |  |               |                        |                  |
| 26   | 21<br>(3050)                      | 14<br>(2030) | 16<br>(2320)                               | 7<br>(1020)   | 7<br>(1020)            | 14<br>(2030)     |
| 33   |                                   |              |  |               |                        |                  |
| 41   |                                   |              |  |               |                        |                  |
| 47   |                                   |              |  |               |                        |                  |
| 53   |                                   |              |  |               |                        |                  |
| 59   |                                   |              |  |               |                        |                  |
| 65   |                                   |              |  |               |                        |                  |
| 52   | 21<br>(3050)                      | 14<br>(2030) | 16<br>(2320)                               | 7<br>(1020)   | 7<br>(1020)            | 14<br>(2030)     |
| 60   |                                   |              |  |               |                        |                  |
| 66   |                                   |              |  |               |                        |                  |
| 76   |                                   |              |  |               |                        |                  |
| 94   |                                   |              |  |               |                        |                  |
| 116  | 16<br>(2320)                      |              |  |               |                        |                  |
| 136  | 17.5<br>(2540)                    | 14<br>(2030) | 16<br>(2320)                               | 7<br>(1020)   | 7<br>(1020)            | 14<br>(2030)     |
| 153  |                                   |              |  |               |                        |                  |
| 184  |                                   |              |  |               |                        |                  |
| 200  |                                   |              |  |               |                        |                  |
| 237  |                                   |              |  |               |                        |                  |

Note: 1) For the relation between model (series) No. and nominal displacement, see the table below.

2) As for PV2R12 and PV2R33 series, the sum of the input powers to small volume pump and large volume pump is limited against shaft speed as follows.

|   |    | Nominal Displacement, Large Volume Pump |            |             |                         |
|---|----|---|------------|-------------|-------------------------|
|   |    | 26, 33, 41, 47, 53, 59, 65              | 52, 60, 66 | 76, 94, 116 | 136, 153, 184, 200, 237 |
| Nominal Displacement, Small Volume Pump | 6  | PV2R12                                  | —          | PV2R13      | PV2R14                  |
|   | 8  |   |            |             |                         |
|   | 10 |   |            |             |                         |
|   | 12 |   |            |             |                         |
|   | 14 |   |            |             |                         |
|   | 17 |   |            |             |                         |
|   | 19 |   |            |             |                         |
|   | 23 |   |            |             |                         |
|   | 25 |   |            |             |                         |
|   | 31 |   |            |             |                         |
| 26                                      | —  | —                                       | —          | PV2R24      |                         |
| 33                                      |    |   |            |             |                         |
| 41                                      |    |   |            |             |                         |
| 47                                      |    |   |            |             | PV2R23                  |
| 53                                      |    |   |            |             |                         |
| 59                                      |    |   |            |             |                         |
| 65                                      | —  | —                                       | —          | PV2R34      |                         |
| 52                                      |    |   |            |             |                         |
| 60                                      |    |   |            |             |                         |
| 66                                      |    |   |            |             |                         |
| 76                                      |    |   |            |             |                         |
| 94                                      | —  | —                                       | PV2R33     | —           |                         |
| 116                                     |    |   |            |             |                         |

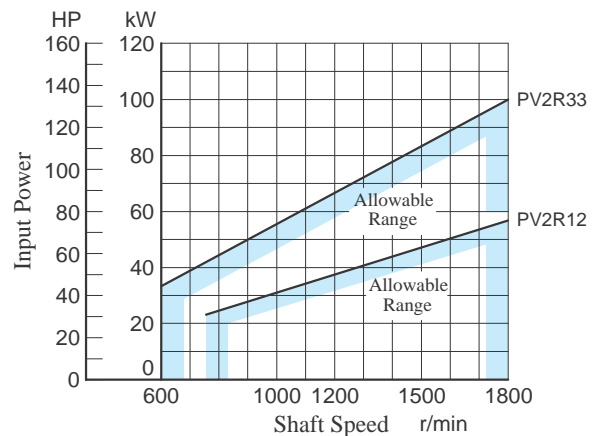

- ★ 1. For the brands of anti-wear type water-glycols, see the item of "Hydraulic Fluids" on page 160.
- ★ 2. For pressures above 16 MPa (2320 PSI), raise the speed over 1450 r/min.
- ★ 3. If nominal displacement "23", of the PV2R14 series is selected, the maximum operating pressure is limited to 16 MPa (2320 PSI).

## ● Shaft Speed Range

| Model Numbers | Shaft Speed Range r/min                    |                   |  |                   |
|---------------|--|-------------------|--|-------------------|
|               | Petroleum Base Oils                        |                   | Water Containing Fluids Phosphate Esters |                   |
|               | Max.                                       | Min.              | Max.                                     | Min.              |
| PV2R12        | 1800                                       | 750 <sup>★3</sup> | 1200                                     | 750 <sup>★3</sup> |
| PV2R13        | 1800 <sup>★2</sup>                         | 750 <sup>★3</sup> | 1200                                     | 750 <sup>★3</sup> |
| PV2R23        | 1800 <sup>★2</sup>                         | 600 <sup>★3</sup> | 1200                                     | 600 <sup>★3</sup> |
| PV2R33        | 1800 <sup>★2</sup><br>(1500) <sup>★1</sup> | 600               | 1200                                     | 600               |
| PV2R14        | 1800 <sup>★2</sup>                         | 750 <sup>★3</sup> | 1200                                     | 750 <sup>★3</sup> |
| PV2R24        | 1800 <sup>★2</sup>                         | 600 <sup>★3</sup> | 1200                                     | 600 <sup>★3</sup> |
| PV2R34        | 1800 <sup>★2</sup>                         | 600               | 1200                                     | 600               |

★1. For PV2R33-116-116, the maximum speed is limited to 1500 r/min.

★2. As for the models (nominal displacements) listed below, the minimum suction pressure are limited in relation to the shaft speed.  
[For other models, the minimum suction pressure is -20 kPa (5.9 in. Hg vacuum) irrespective of speed.]

| Model Numbers  | Min. Suction Pres. kPa (in. Hg Vacuum) |                   |
|--|--|-------------------|
|  | Less than 1700 r/min                   | 1700 - 1800 r/min |
| PV2R13-*-116<br>PV2R23-*-116                               | -20 (5.9)                              | 0 (0)             |
| PV2R23-*-76<br>PV2R23-*-94<br>PV2R33-*-76                  | -20 (5.9)                              | -7 (1.97)         |
| PV2R33-94-*<br>PV2R33-116-*<br>PV2R33-*-94<br>PV2R33-*-116 | -20 (5.9)                              | 0 (0)             |
| PV2R14-*-237<br>PV2R24-*-237<br>PV2R34-*-237               | -20 (5.9)                              | -13 (3.94)        |
| PV2R34-116-*   | -20 (5.9)                              | 0 (0)             |

★3. For starting at low speed, the maximum viscosity is limited.  
For details, see the item of "Hydraulic Fluids" on page 160.

## ● Output Flow & Input Power

The pump characteristics are the same as those for PV2R series single pumps. See the pages concerned.

| Model Numbers | Output Flow & Input Power   |   |
|---------------|---|---|
|               | Small Volume Pump   | Large Volume Pump   |
| PV2R12        | Same as single pump "PV2R1", refer to pages 170 - 172.  | Same as single pump "PV2R2", refer to pages 172 & 173.<br>However, as for displacement of "26" and "33", refer to page 192.       |
| PV2R13        | Same as single pump "PV2R1", refer to pages 170 - 172.  | Same as single pump "PV2R3", refer to page 174.   |
| PV2R23        | Same as single pump "PV2R2", refer to pages 172 & 173.  | Same as single pump "PV2R3", refer to page 174.<br>However, as for displacement of "52", "60" and "66", refer to pages 192 & 193. |
| PV2R33        | Same as single pump "PV2R3", refer to page 174.   | Same as single pump "PV2R3", refer to page 174.   |
| PV2R14        | Same as single pump "PV2R1", refer to pages 170 & 171.  | Same as single pump "PV2R4", refer to pages 174 & 175.  |
| PV2R24        | Same as single pump "PV2R2", refer to page 172<br>However, as for displacement of "26" and "33", refer to page 192.               |   |
| PV2R34        | Same as single pump "PV2R3", refer to page 174.<br>However, as for displacement of "52", "60" and "66", refer to pages 192 & 193. |   |

## ● Mass

| Mounting    | Model Numbers | Approx. Mass kg (lbs.) |            |          |          |           |           |           |
|-------------|---------------|------------------------|------------|----------|----------|-----------|-----------|-----------|
|             |               | PV2R12                 | PV2R13     | PV2R23   | PV2R33   | PV2R14    | PV2R24    | PV2R34    |
| Flange Mtg. |               | 25 (55.1)              | 45.6 (101) | 51 (112) | 84 (185) | 75 (165)  | 78 (172)  | 98 (216)  |
| Foot Mtg.   |               | 29.3 (64.6)            | 55.6 (123) | 61 (135) | 94 (207) | 100 (221) | 103 (227) | 123 (271) |



## ■ Pipe Flange Kits

Pipe flange kits are available. When ordering, specify the kit the number from the table below.

| Pump Model Numbers | Name of Port    | Pipe Flange Kit Numbers |                          |   |   |   |   |   |
|--------------------|-----------------|-------------------------|--------------------------|---|---|---|---|---|
|                    |                 | Threaded Connection     |                          |   | Socket Welding <sup>★1</sup>                        |   | Butt Welding  |   |
|                    |                 | Japanese Standard "JIS" | European Design Standard | N. American Design Standard <sup>★2</sup> | Japanese Standard "JIS"<br>European Design Standard | N. American Design Standard <sup>★2</sup> | Japanese Standard "JIS"<br>European Design Standard | N. American Design Standard <sup>★2</sup> |
| PV2R12             | Suction         | F5-16-A-10              | F5-16-A-1080             | —   | F5-16-B-10  | F5-16-B-1090                              | F5-16-C-10  | F5-16-C-1090                              |
|                    | Large Discharge | F5-06-A-10              | F5-06-A-1080             | —   | F5-06-B-10  | F5-06-B-1090                              | F5-06-C-10  | F5-06-C-1090                              |
|                    | Small Discharge | F5-04-A-10              | F5-04-A-1080             | —   | F5-04-B-10  | F5-04-B-1090                              | F5-04-C-10  | F5-04-C-1090                              |
| PV2R13             | Suction         | F5-24-A-10              | —                        | —   | F5-24-B-10  | F5-24-B-1090                              | F5-24-C-10  | F5-24-C-1090                              |
|                    | Large Discharge | F5-10-A-10              | F5-10-A-1080             | —   | F5-10-B-10  | F5-10-B-1090                              | F5-10-C-10  | F5-10-C-1090                              |
|                    | Small Discharge | F5-04-A-10              | F5-04-A-1080             | —   | F5-04-B-10  | F5-04-B-1090                              | F5-04-C-10  | F5-04-C-1090                              |
| PV2R23             | Suction         | F5-24-A-10              | —                        | —   | F5-24-B-10  | F5-24-B-1090                              | F5-24-C-10  | F5-24-C-1090                              |
|                    | Large Discharge | F5-10-A-10              | F5-10-A-1080             | —   | F5-10-B-10  | F5-10-B-1090                              | F5-10-C-10  | F5-10-C-1090                              |
|                    | Small Discharge | F5-06-A-10              | F5-06-A-1080             | —   | F5-06-B-10  | F5-06-B-1090                              | F5-06-C-10  | F5-06-C-1090                              |
| PV2R33             | Suction         | F5-28-A-10              | —                        | —   | F5-28-B-10  | F5-28-B-1090                              | F5-28-C-10  | F5-28-C-1090                              |
|                    | Large Discharge | F5-10-A-10              | F5-10-A-1080             | —   | F5-10-B-10  | F5-10-B-1090                              | F5-10-C-10  | F5-10-C-1090                              |
|                    | Small Discharge | F5-10-A-10              | F5-10-A-1080             | —   | F5-10-B-10  | F5-10-B-1090                              | F5-10-C-10  | F5-10-C-1090                              |
| PV2R14             | Suction         | F5-28-A-10              | —                        | —   | F5-28-B-10  | F5-28-B-1090                              | F5-28-C-10  | F5-28-C-1090                              |
|                    | Large Discharge | F5-12-A-10              | F5-12-A-1080             | —   | F5-12-B-10  | F5-12-B-1090                              | F5-12-C-10  | F5-12-C-1090                              |
|                    | Small Discharge | F5-04-A-10              | F5-04-A-1080             | —   | F5-04-B-10  | F5-04-B-1090                              | F5-04-C-10  | F5-04-C-1090                              |
| PV2R24             | Suction         | F5-28-A-10              | —                        | —   | F5-28-B-10  | F5-28-B-1090                              | F5-28-C-10  | F5-28-C-1090                              |
|                    | Large Discharge | F5-12-A-10              | F5-12-A-1080             | —   | F5-12-B-10  | F5-12-B-1090                              | F5-12-C-10  | F5-12-C-1090                              |
|                    | Small Discharge | F5-06-A-10              | F5-06-A-1080             | —   | F5-06-B-10  | F5-06-B-1090                              | F5-06-C-10  | F5-06-C-1090                              |
| PV2R34             | Suction         | F5-32-A-10              | —                        | —   | F5-32-B-10  | F5-32-B-1090                              | F5-32-C-10  | F5-32-C-1090                              |
|                    | Large Discharge | F5-12-A-10              | F5-12-A-1080             | —   | F5-12-B-10  | F5-12-B-1090                              | F5-12-C-10  | F5-12-C-1090                              |
|                    | Small Discharge | F5-10-A-10              | F5-10-A-1080             | —   | F5-10-B-10  | F5-10-B-1090                              | F5-10-C-10  | F5-10-C-1090                              |

★1. In case of using socket welding flanges, there is a case where the operating pressure should be set lower than the normal because of strength of the flanges. Therefore, please pay cautious attention to the operating pressure when the socket welding flanges are used.

★2. As dimensions of the pipe flange mounting surface are conformed to SAE 4 Bolt Split Flange (Standard Pressure Series), pipe flanges conforming to the SAE Standards can be used.

Notes: Special seals (Viton seals) are required when phosphate ester type fluids are used. (Prefix "F-" to the pipe flange kit number when ordering.)

● Details of the pipe flange kits are shown on [page 824](#).



Flange Mtg.: PV2R12-\*\*-F-REAA-42/4290

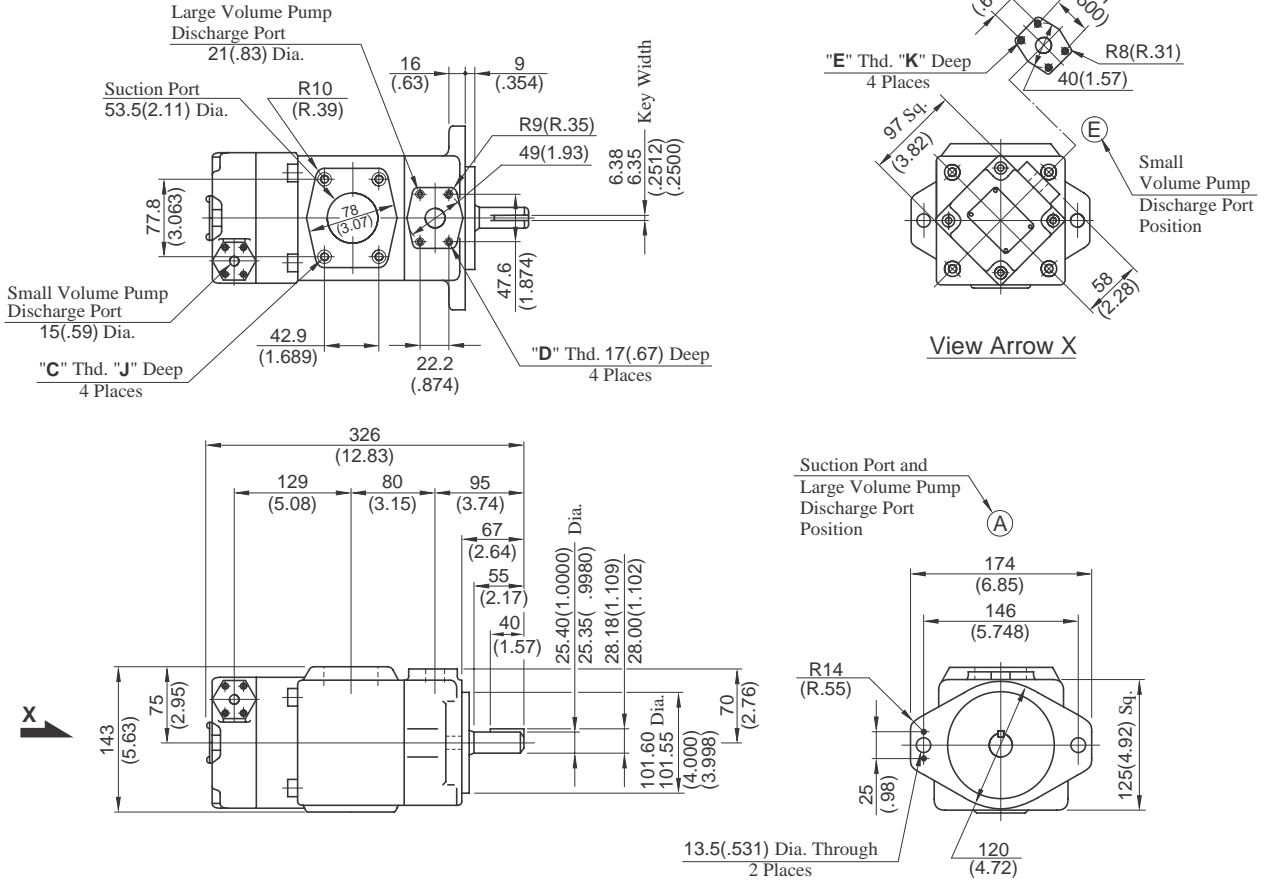

| Model Numbers         | "C" Thd.   | "D" Thd.   | "E" Thd.    | Dimensions mm (Inches) |          |
|-----------------------|------------|------------|-------------|------------------------|----------|
|                       |            |            |             | J                      | K        |
| PV2R12-**-F-REAA-42   | M12        | M10        | M8          | 19 (.75)               | 14 (.55) |
| PV2R12-**-F-REAA-4290 | 1/2-13 UNC | 3/8-16 UNC | 5/16-18 UNC | 21 (.83)               | 16 (.63) |

DIMENSIONS IN MILLIMETRES (INCHES)

Foot Mtg.: PV2R12-\*\*-L-REAA-42/4290

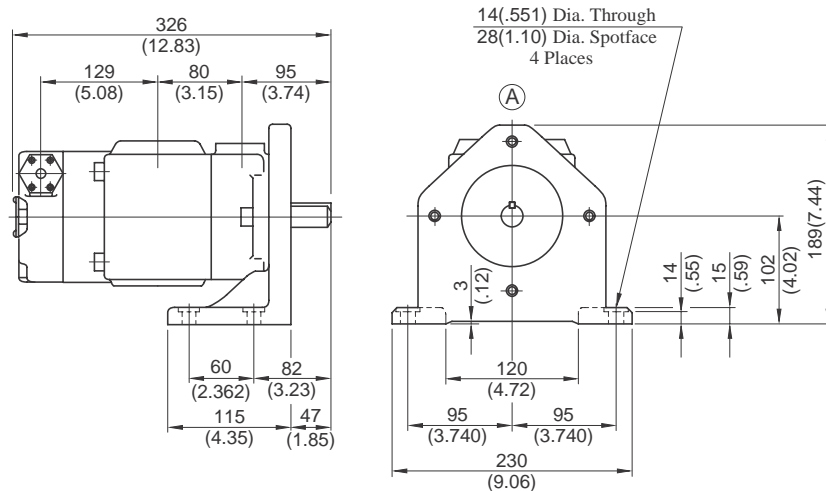

• For other dimensions, refer to "Flange Mtg."

**Flange Mtg.: PV2R13-\*\*-F-RAAA-42/4290**

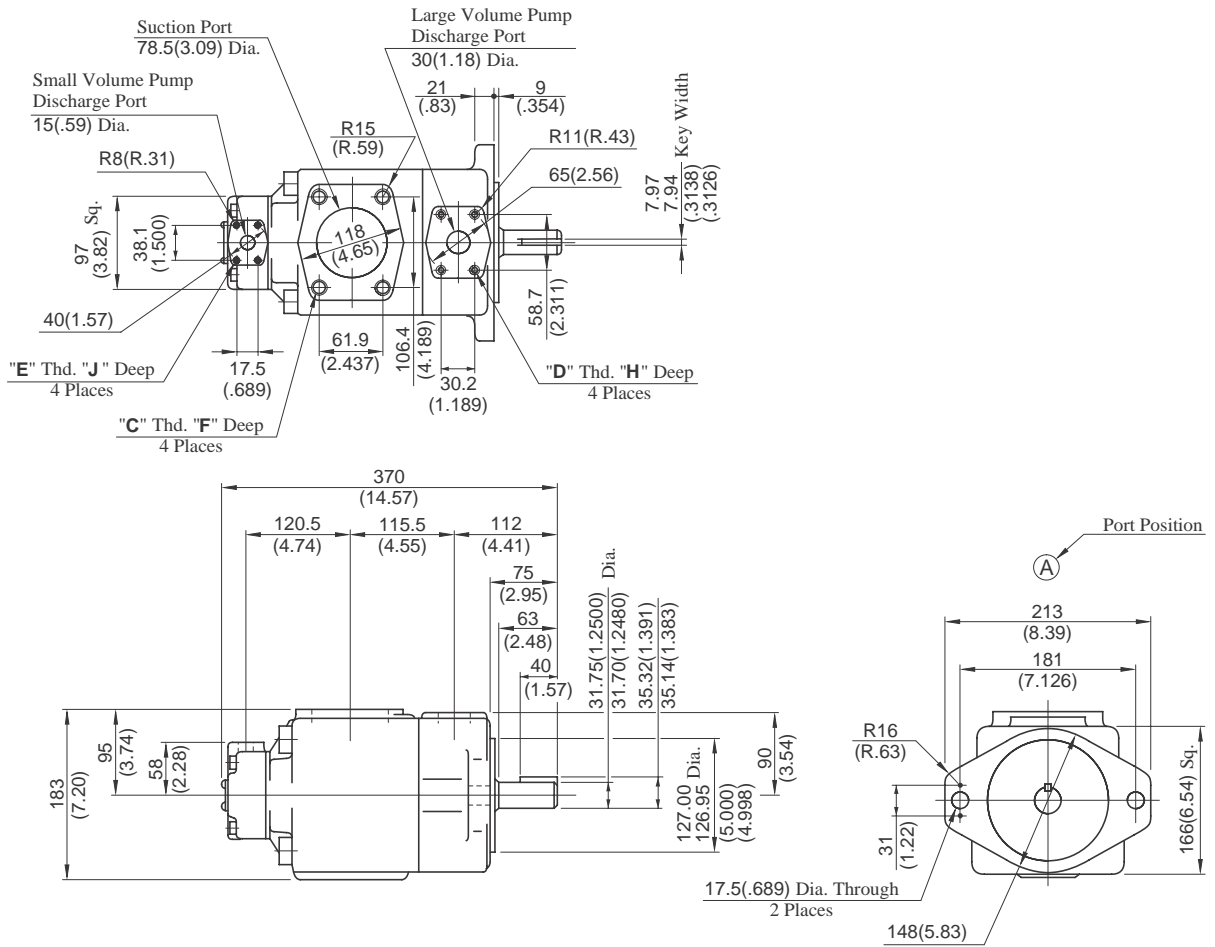

| Model Numbers         | "C" Thd.   | "D" Thd.    | "E" Thd.    | Dimensions mm (Inches) |          |          |
|-----------------------|------------|-------------|-------------|------------------------|----------|----------|
|                       |            |             |             | F                      | H        | J        |
| PV2R13-**-F-RAAA-42   | M16        | M10         | M8          | 19 (.75)               | 19 (.75) | 14 (.55) |
| PV2R13-**-F-RAAA-4290 | 5/8-11 UNC | 7/16-14 UNC | 5/16-18 UNC | 21 (.83)               | 20 (.79) | 16 (.63) |

**DIMENSIONS IN MILLIMETRES (INCHES)**

**Foot Mtg.: PV2R13-\*\*-L-RAAA-42/4290**

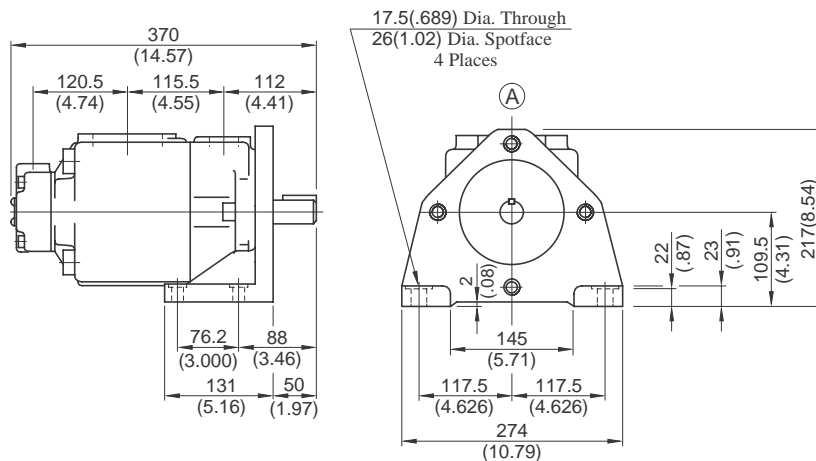

• For other dimensions, refer to "Flange Mtg.".

Flange Mtg.: PV2R23-\*-F-REAA-41/4190

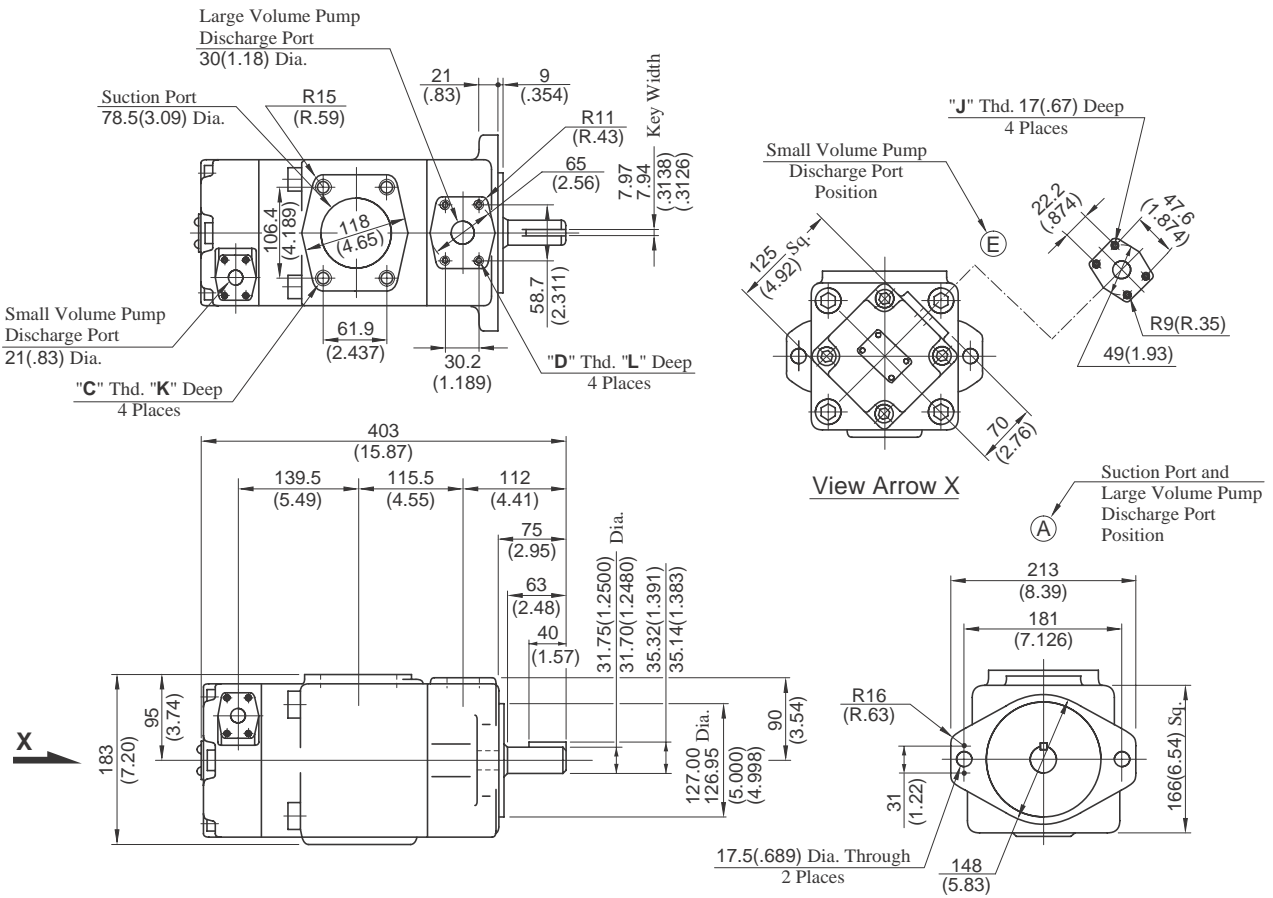

DIMENSIONS IN  
MILLIMETRES (INCHES)

Foot Mtg.: PV2R23-\*-L-REAA-41/4190

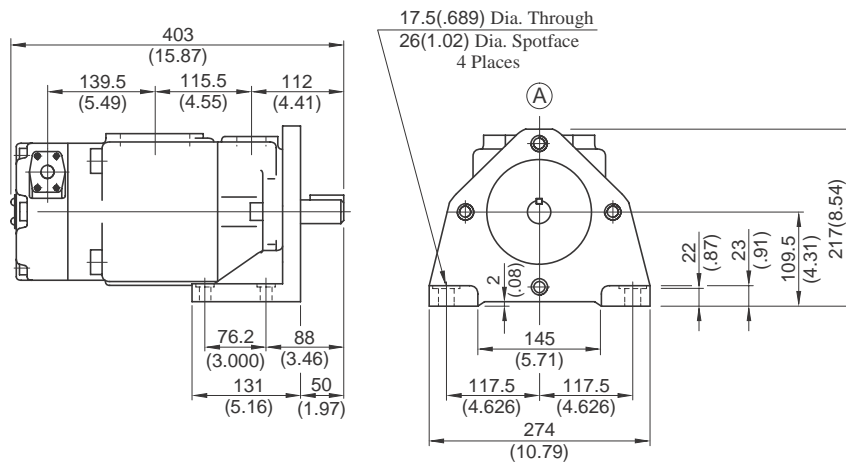

• For other dimensions, refer to "Flange Mtg.".

Flange Mtg.: PV2R33-\*\*-F-RAAA-31/3190

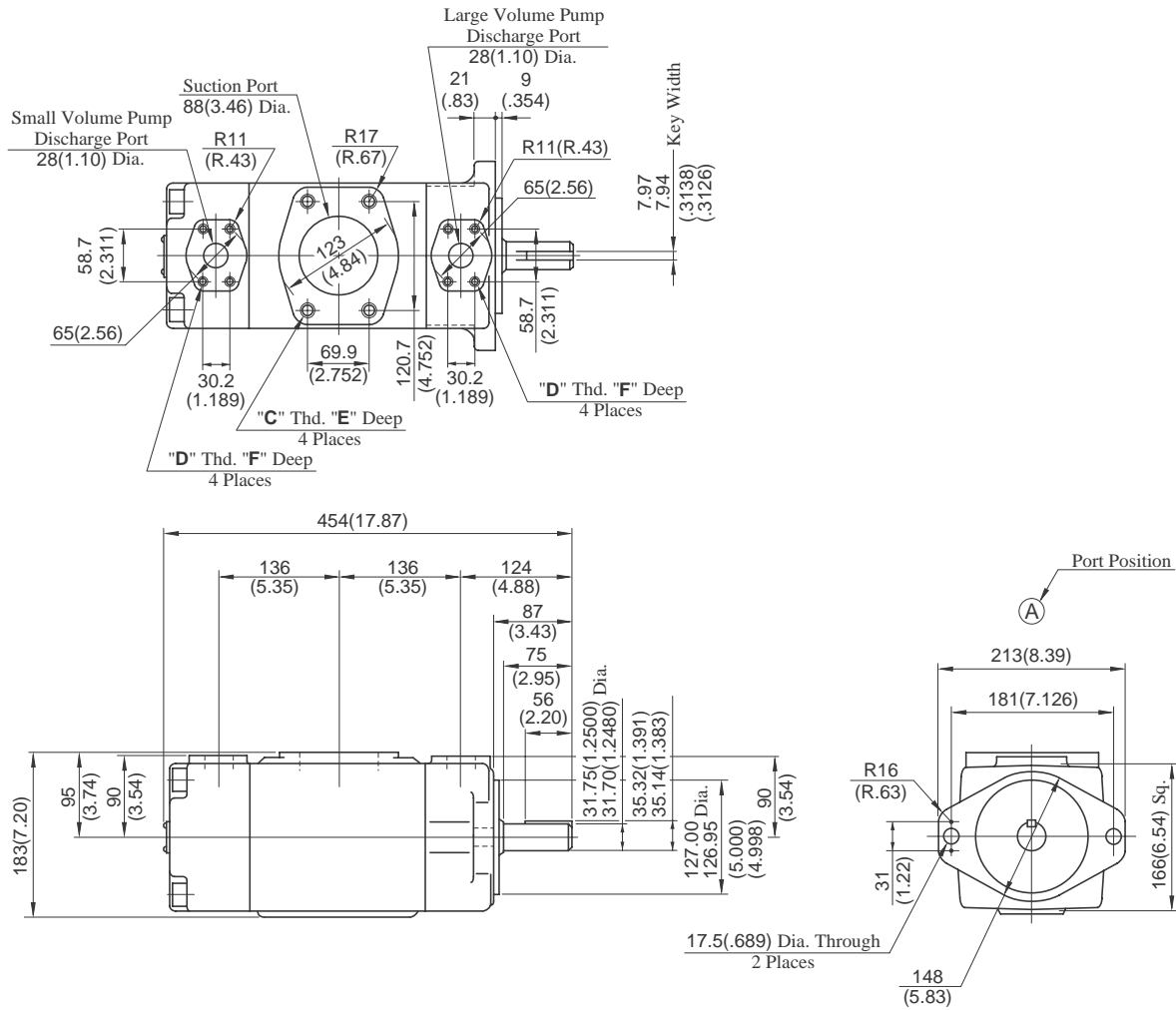

**DIMENSIONS IN MILLIMETRES (INCHES)**

Foot Mtg.: PV2R33-\*\*-L-RAAA-31/3190

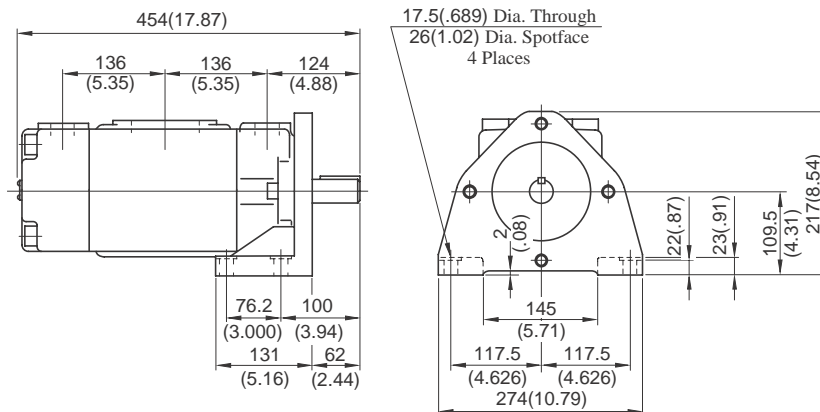

• For other dimensions, refer to "Flange Mtg.".



Flange Mtg.: PV2R14-\*\*-F-RAAA-32/3290

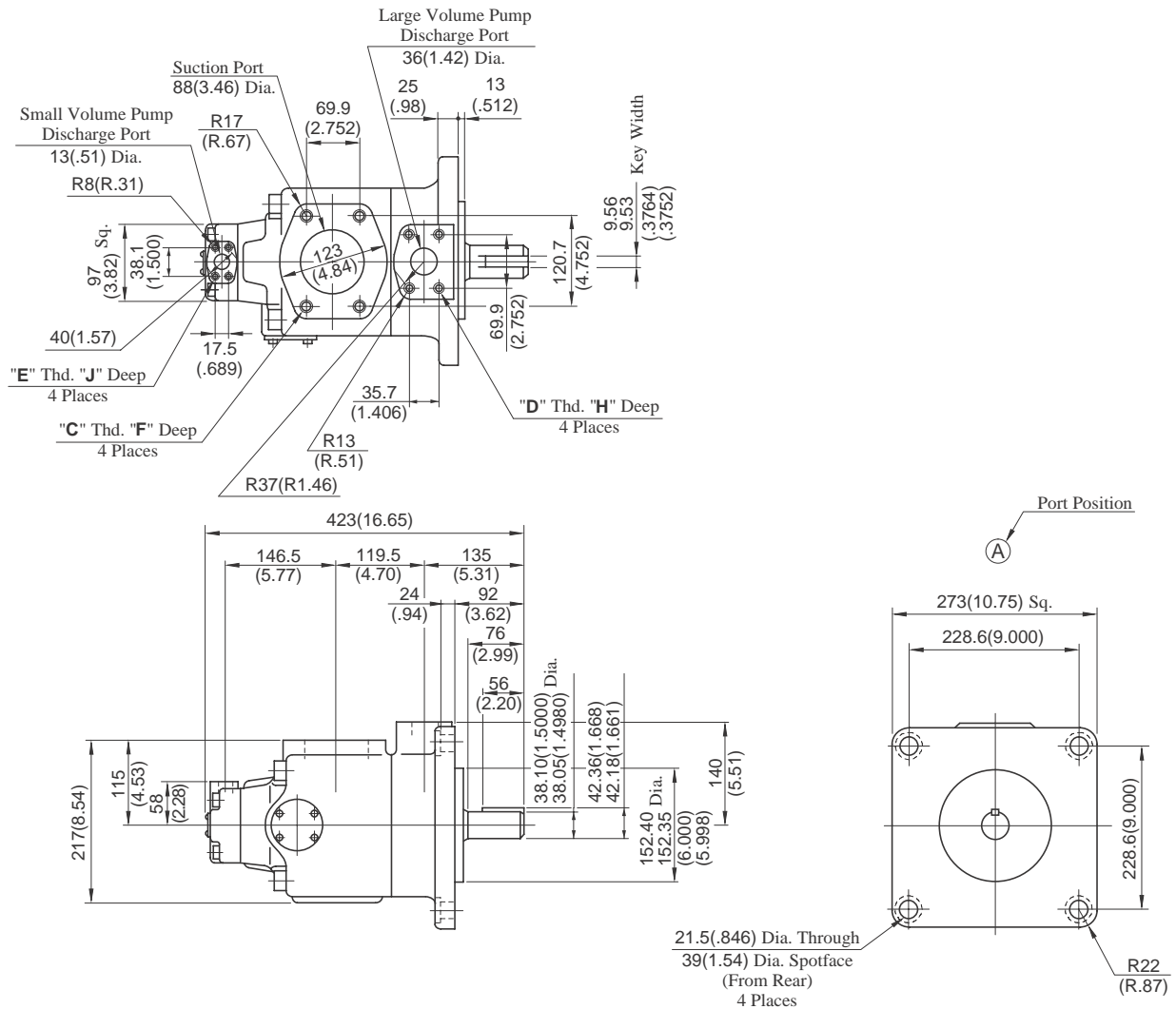

| Model Numbers         | "C" Thd.   | "D" Thd.   | "E" Thd.    | Dimensions mm (Inches) |          |          |
|-----------------------|------------|------------|-------------|------------------------|----------|----------|
|                       |            |            |             | F                      | H        | J        |
| PV2R14-**-F-RAAA-32   | M16        | M12        | M8          | 19 (.75)               | 19 (.75) | 14 (.55) |
| PV2R14-**-F-RAAA-3290 | 5/8-11 UNC | 1/2-13 UNC | 5/16-18 UNC | 21 (.83)               | 21 (.83) | 16 (.63) |

DIMENSIONS IN MILLIMETRES (INCHES)

Foot Mtg.: PV2R14-\*\*-L-RAAA-32/3290

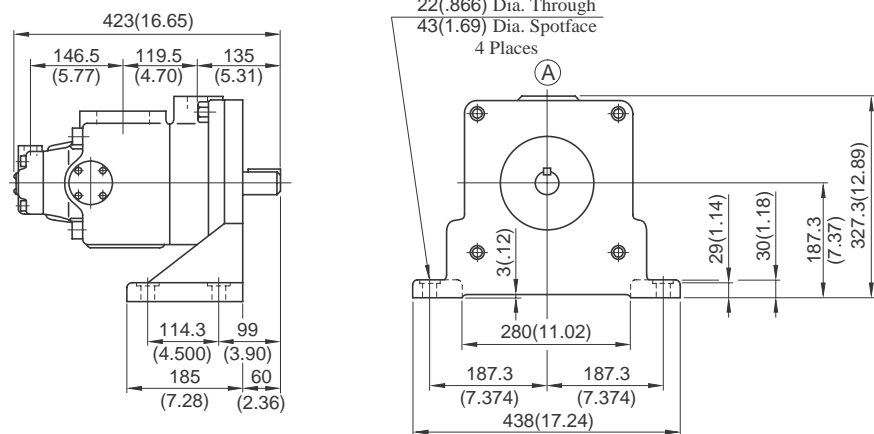

• For other dimensions, refer to "Flange Mtg.".

**Flange Mtg.: PV2R24-\*-F-RAAA-31/3190**

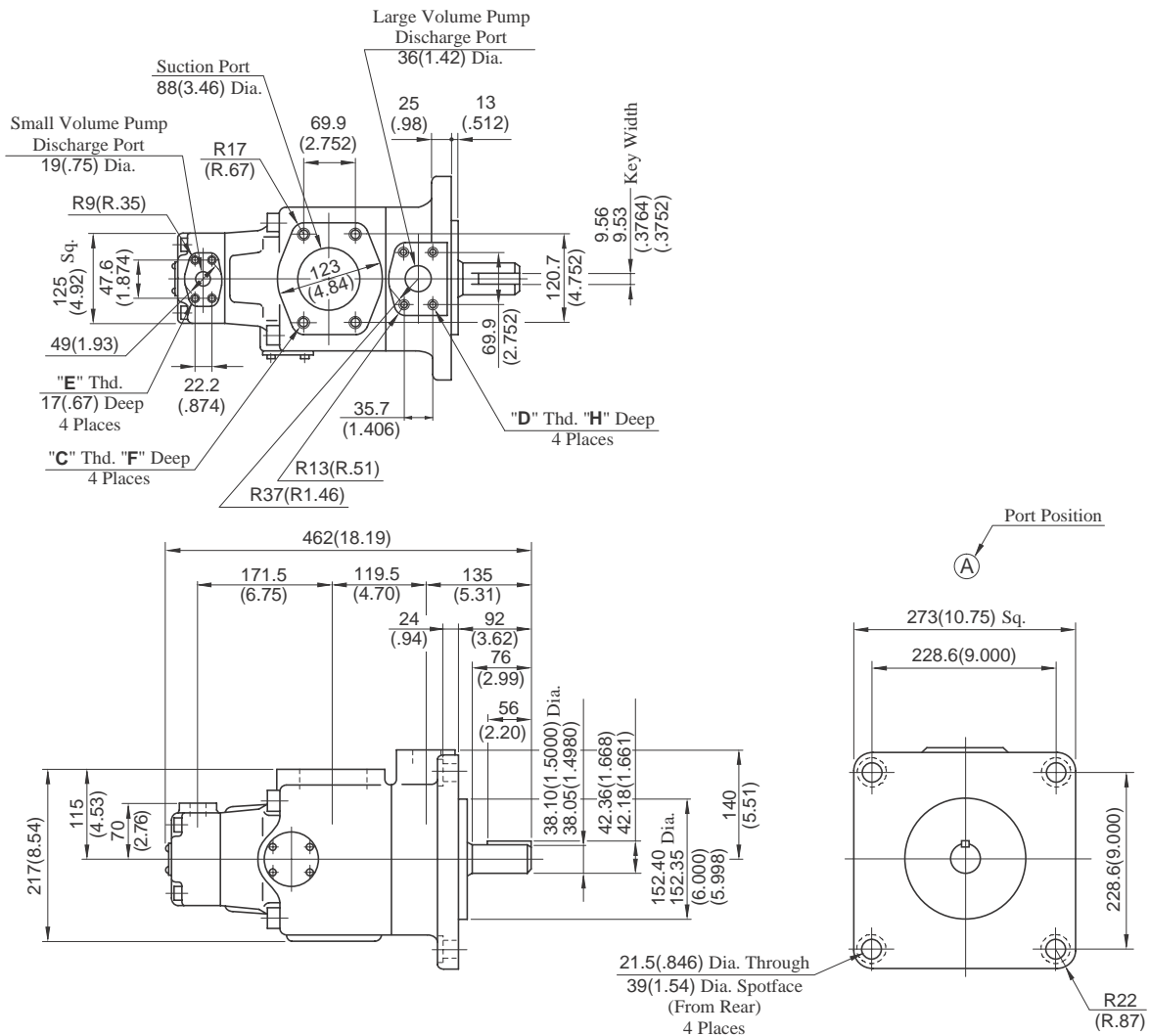

| Model Numbers        | "C" Thd.   | "D" Thd.   | "E" Thd.   | Dimensions mm (Inches) |          |
|----------------------|------------|------------|------------|------------------------|----------|
|                      |            |            |            | F                      | H        |
| PV2R24-*-F-RAAA-31   | M16        | M12        | M10        | 19 (.75)               | 19 (.75) |
| PV2R24-*-F-RAAA-3190 | 5/8-11 UNC | 1/2-13 UNC | 3/8-16 UNC | 21 (.83)               | 21 (.83) |

**DIMENSIONS IN MILLIMETRES (INCHES)**

**Foot Mtg.: PV2R24-\*-L-RAAA-31/3190**

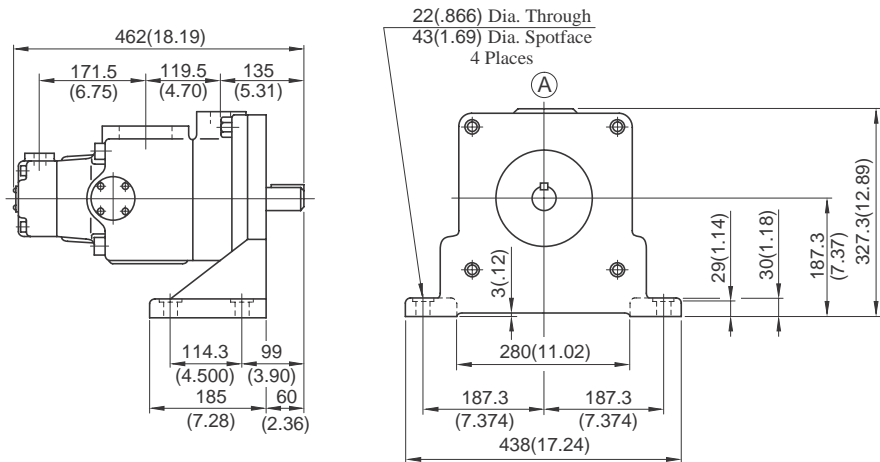

• For other dimensions, refer to "Flange Mtg.".

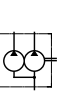

Flange Mtg.: PV2R34-\*\*-F-REAA-31/3190

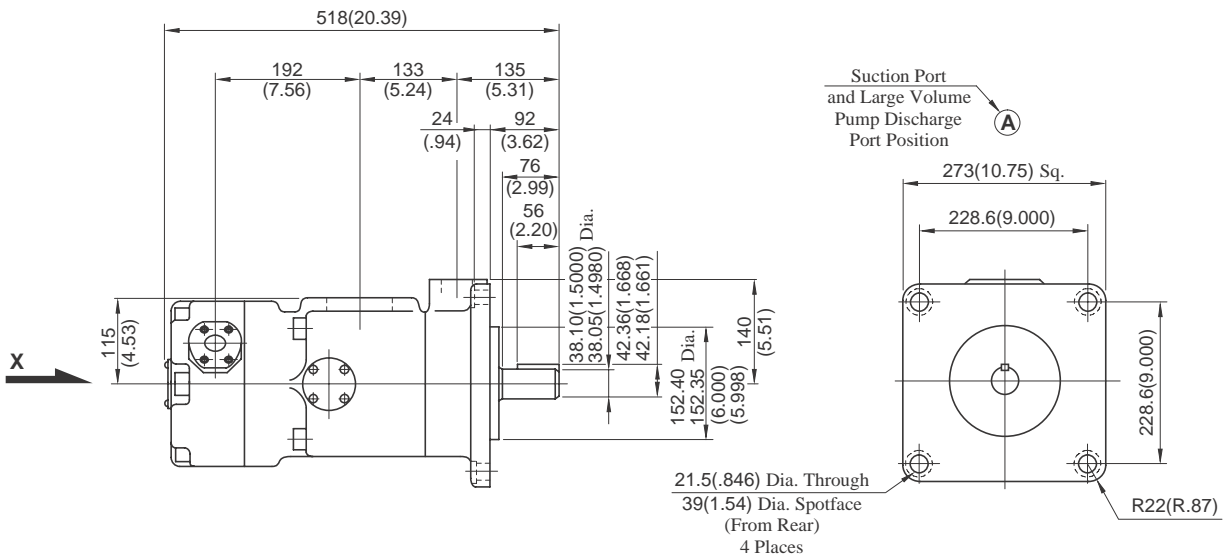
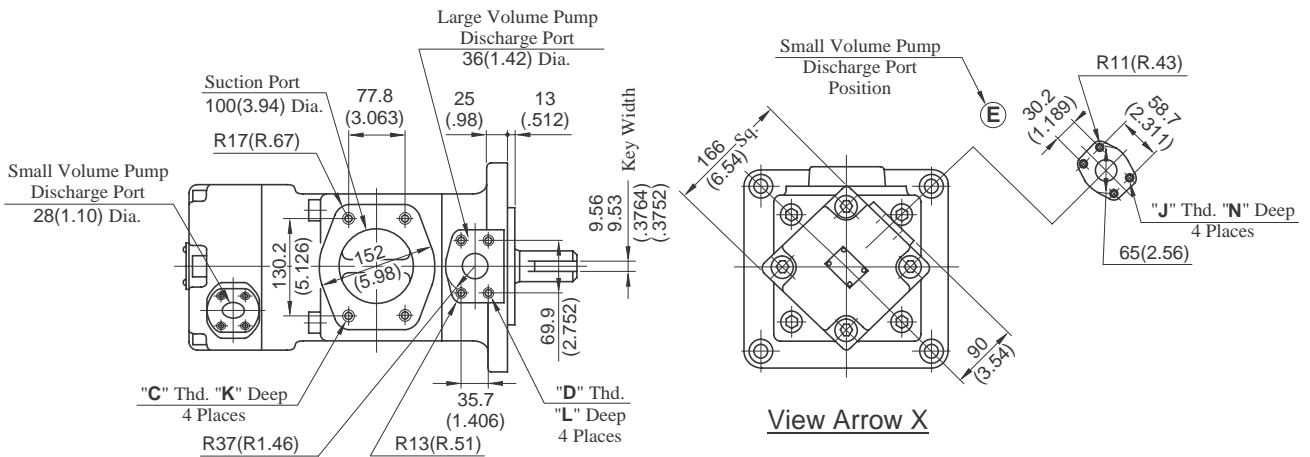

| Model Numbers         | "C" Thd.   | "D" Thd.   | "J" Thd.    | Dimensions mm (Inches) |          |          |
|-----------------------|------------|------------|-------------|------------------------|----------|----------|
|                       |            |            |             | K                      | L        | N        |
| PV2R34-**-F-REAA-31   | M16        | M12        | M8          | 19 (.75)               | 19 (.75) | 19 (.75) |
| PV2R34-**-F-REAA-3190 | 5/8-11 UNC | 1/2-13 UNC | 7/16-14 UNC | 21 (.83)               | 21 (.83) | 20 (.79) |

DIMENSIONS IN MILLIMETRES (INCHES)

Foot Mtg.: PV2R34-\*\*-L-REAA-31/3190

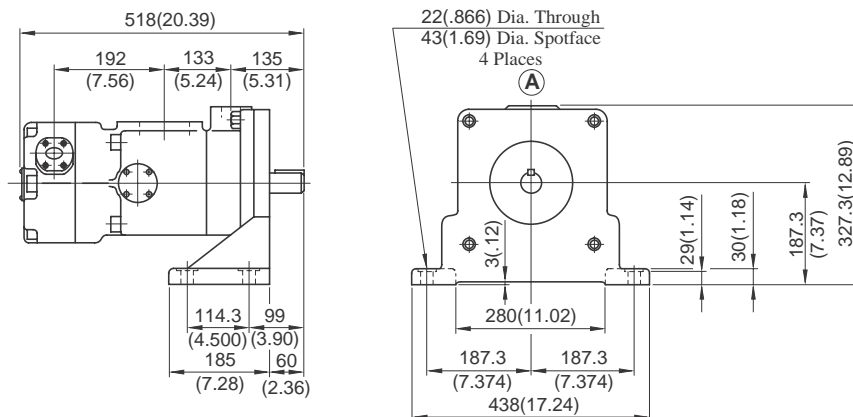

• For other dimensions, refer to "Flange Mtg."

Typical Pump Characteristics at Viscosity 20 mm<sup>2</sup>/s (100 SSU) [ISO VG32 Oils, 50°C (122°F)]

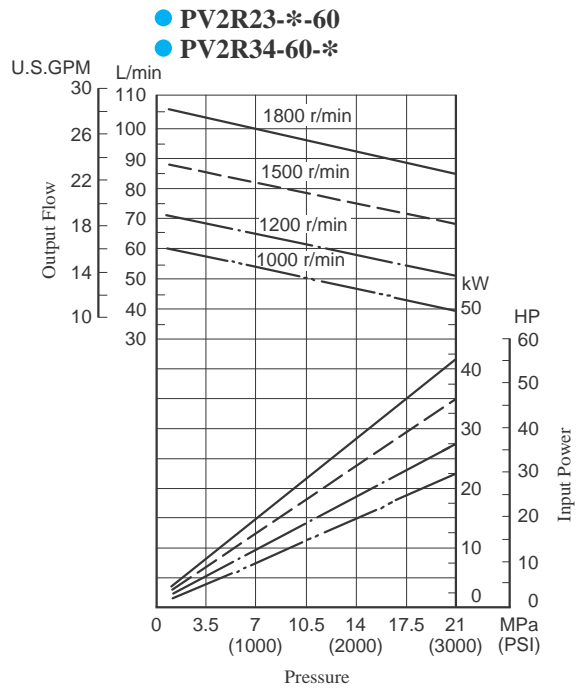
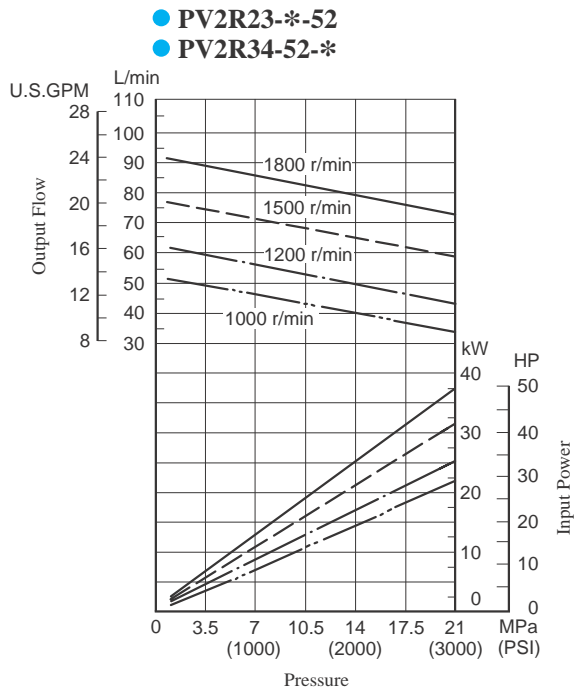
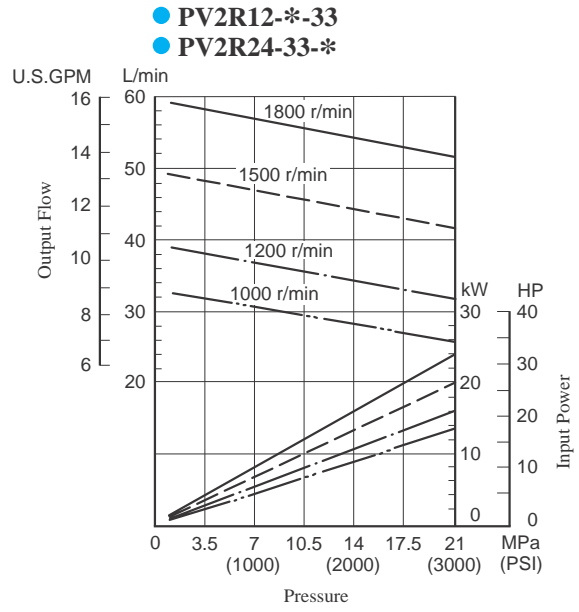
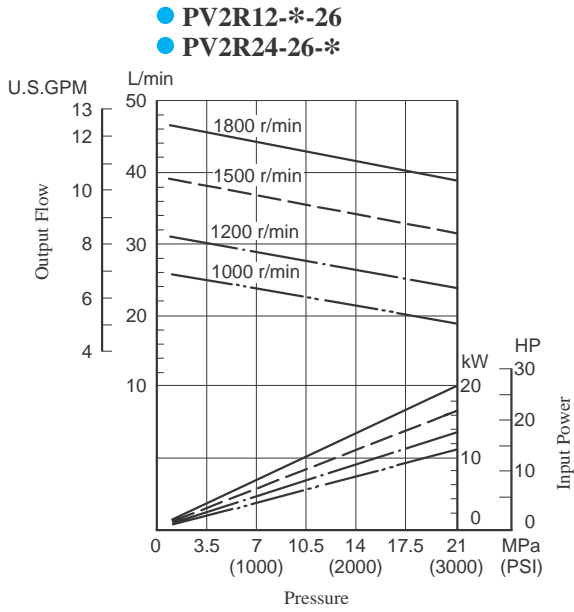

Typical Pump Characteristics at Viscosity 20 mm<sup>2</sup>/s (100 SSU) [ISO VG32 Oils, 50°C (122°F)]

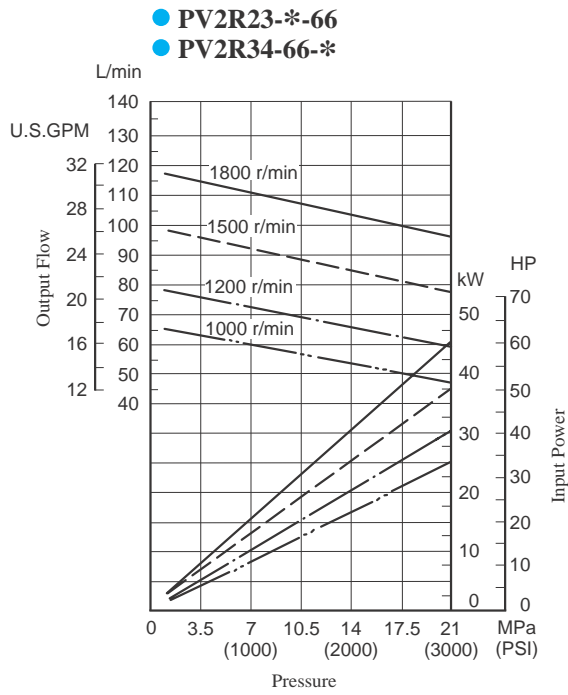

**Spare Parts List**

PV2R12-\*\*-\*\*-REAA-42/4290  
 PV2R13-\*\*-\*\*-RAAA-42/4290  
 PV2R23-\*\*-\*\*-REAA-41/4190  
 PV2R33-\*\*-\*\*-RAAA-31/3190

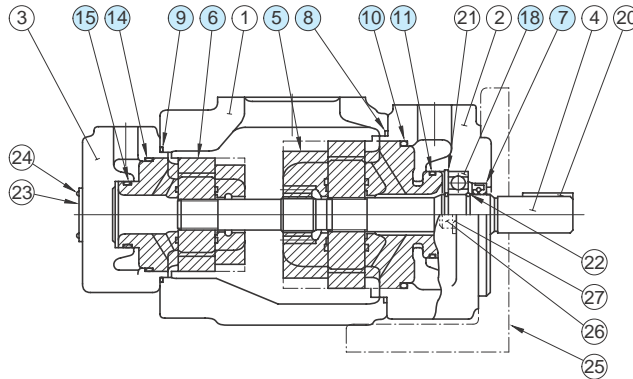

**Cartridge Kits**

| Model Numbers           | Cartridge Kit Numbers |                     | Model Numbers            | Cartridge Kit Numbers |                     |
|-------------------------|-----------------------|---------------------|--------------------------|-----------------------|---------------------|
|                         | ⑥ Small Volume Pump   | ⑤ Large Volume Pump |                          | ⑥ Small Volume Pump   | ⑤ Large Volume Pump |
| PV2R12-6-★-**-REAA-42*  | CPV2R13-6-L-42        | CPV2R2<br>-★-R-41   | PV2R13-6-★-**-RAAA-42*   | CPV2R13-6-L-42        | CPV2R3<br>-★-R-31   |
| PV2R12-8-★-**-REAA-42*  | CPV2R13-8-L-42        |                     | PV2R13-8-★-**-RAAA-42*   | CPV2R13-8-L-42        |                     |
| PV2R12-10-★-**-REAA-42* | CPV2R13-10-L-42       |                     | PV2R13-10-★-**-RAAA-42*  | CPV2R13-10-L-42       |                     |
| PV2R12-12-★-**-REAA-42* | CPV2R13-12-L-42       |                     | PV2R13-12-★-**-RAAA-42*  | CPV2R13-12-L-42       |                     |
| PV2R12-14-★-**-REAA-42* | CPV2R13-14-L-42       |                     | PV2R13-14-★-**-RAAA-42*  | CPV2R13-14-L-42       |                     |
| PV2R12-17-★-**-REAA-42* | CPV2R13-17-L-42       |                     | PV2R13-17-★-**-RAAA-42*  | CPV2R13-17-L-42       |                     |
| PV2R12-19-★-**-REAA-42* | CPV2R13-19-L-42       |                     | PV2R13-19-★-**-RAAA-42*  | CPV2R13-19-L-42       |                     |
| PV2R12-23-★-**-REAA-42* | CPV2R13-23-L-42       |                     | PV2R13-23-★-**-RAAA-42*  | CPV2R13-23-L-42       |                     |
| PV2R12-25-★-**-REAA-42* | CPV2R13-25-L-42       |                     | PV2R13-25-★-**-RAAA-42*  | CPV2R13-25-L-42       |                     |
| PV2R12-31-★-**-REAA-42* | CPV2R13-31-L-42       |                     | PV2R13-31-★-**-RAAA-42*  | CPV2R13-31-L-42       |                     |
| PV2R23-41-★-**-REAA-41* | CPV2R23-41-L-41       | CPV2R33<br>-★-R-31  | PV2R33-76-★-**-RAAA-31*  | CPV2R33-76-L-31       | CPV2R33<br>-★-R-31  |
| PV2R23-47-★-**-REAA-41* | CPV2R23-47-L-41       |                     | PV2R33-94-★-**-RAAA-31*  | CPV2R33-94-L-31       |                     |
| PV2R23-53-★-**-REAA-41* | CPV2R23-53-L-41       |                     | PV2R33-116-★-**-RAAA-31* | CPV2R33-116-L-31      |                     |
| PV2R23-59-★-**-REAA-41* | CPV2R23-59-L-41       |                     |                          |                       |                     |
| PV2R23-65-★-**-REAA-41* | CPV2R23-65-L-41       |                     |                          |                       |                     |

Note: The ★ marks are a spaces for large volume pump nominal displacement. Referring to the model No. designation on page 181, write the correct nominal displacement figures.

**Seals & Bearings**

| Item | Name of Parts | Part Numbers |              |              |              | Qty. |
|------|---------------|--------------|--------------|--------------|--------------|------|
|      |               | PV2R12       | PV2R13       | PV2R23       | PV2R33       |      |
| 7★   | Oil Seal      | ISD 30 42 8  | ISD 35 55 11 | ISD 35 55 11 | ISD 35 55 11 | 1    |
| 8★   | O-Ring        | SO-NB-G105   | SO-NB-G135   | SO-NB-G135   | SO-NB-G135   | 1    |
| 9★   | O-Ring        | SO-NB-G80    | SO-NB-G80    | SO-NB-G105   | SO-NB-G135   | 1    |
| 10★  | O-Ring        | SO-NB-G85    | SO-NB-G115   | SO-NB-G115   | SO-NB-G115   | 1    |
| 11★  | O-Ring        | SO-NB-P46    | SO-NB-A231   | SO-NB-A231   | SO-NB-A231   | 1    |
| 14★  | O-Ring        | SO-NB-G60    | SO-NB-G60    | SO-NB-G85    | SO-NB-G115   | 1    |
| 15★  | O-Ring        | SO-NB-G30    | SO-NB-G30    | SO-NB-P46    | SO-NB-A231   | 1    |
| 18   | Bearing       | 6205         | 6207         | 6207         | 6207         | 1    |
| 19   | Bearing       | —            | —            | —            | 6305         | 1    |

Note: 1) The o-rings under item. Nos. ⑩ and ⑪ are included in the large volume pump cartridge kit and those under item. Nos. ⑭ and ⑮ in the small volume pump cartridge kit.

2) For pumps for phosphate ester type hydraulic fluids, different part Nos. are used. Please contact us.

★ When ordering seals, please specify the seal kit number from the table right.

**List of Seal Kits**

| Pump Model Numbers    | Seal Kit Numbers |
|-----------------------|------------------|
| PV2R12-**-**-REAA-42* | KS-PV2R12-40     |
| PV2R13-**-**-RAAA-42* | KS-PV2R13-40     |
| PV2R23-**-**-REAA-41* | KS-PV2R23-40     |
| PV2R33-**-**-RAAA-31* | KS-PV2R33-30     |



## Spare Parts List

PV2R14-\*\*-\*\*-RAAA-32/3290  
 PV2R24-\*\*-\*\*-RAAA-31/3190  
 PV2R34-\*\*-\*\*-REAA-31/3190

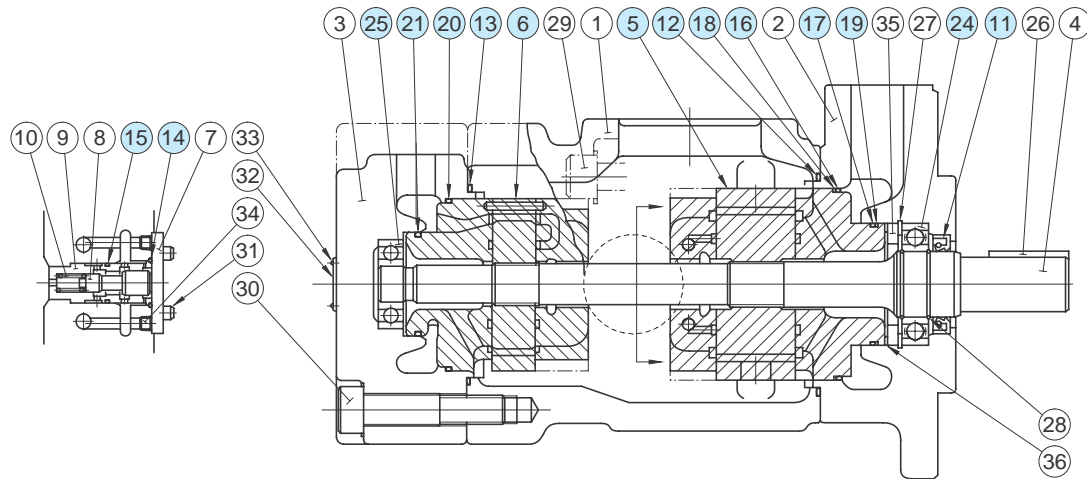

### Cartridge Kits

| Model Numbers           | Cartridge Kit Numbers |                          | Model Numbers           | Cartridge Kit Numbers |                     |
|-------------------------|-----------------------|--------------------------|-------------------------|-----------------------|---------------------|
|                         | ⑥ Small Volume Pump   | ⑤ Large Volume Pump      |                         | ⑥ Small Volume Pump   | ⑤ Large Volume Pump |
| PV2R14-6-★-**-RAAA-32*  | CPV2R13-6-L-42        | CPV2R2<br>-★-R-41        | PV2R24-26-★-**-RAAA-31* | CPV2R23-26-L-41       | CPV2R4<br>-★-R-30   |
| PV2R14-8-★-**-RAAA-32*  | CPV2R13-8-L-42        |                          | PV2R24-33-★-**-RAAA-31* | CPV2R23-33-L-41       |                     |
| PV2R14-10-★-**-RAAA-32* | CPV2R13-10-L-42       |                          | PV2R24-41-★-**-RAAA-31* | CPV2R23-41-L-41       |                     |
| PV2R14-12-★-**-RAAA-32* | CPV2R13-12-L-42       |                          | PV2R24-47-★-**-RAAA-31* | CPV2R23-47-L-41       |                     |
| PV2R14-14-★-**-RAAA-32* | CPV2R13-14-L-42       |                          | PV2R34-52-★-**-REAA-31* | CPV2R33-52-L-31       | CPV2R34<br>-★-R-31  |
| PV2R14-17-★-**-RAAA-32* | CPV2R13-17-L-42       |                          | PV2R34-60-★-**-REAA-31* | CPV2R33-60-L-31       |                     |
| PV2R14-19-★-**-RAAA-32* | CPV2R13-19-L-42       |                          | PV2R34-66-★-**-REAA-31* | CPV2R33-66-L-31       |                     |
| PV2R14-23-★-**-RAAA-32* | CPV2R13-23-L-42       |                          | PV2R34-76-★-**-REAA-31* | CPV2R33-76-L-31       |                     |
|                         |                       | PV2R34-94-★-**-REAA-31*  | CPV2R33-94-L-31         |                       |                     |
|                         |                       | PV2R34-116-★-**-REAA-31* | CPV2R33-116-L-31        |                       |                     |

Note: The ★ marks are a spaces for large volume pump nominal displacement. Referring to the model No. designation on page 181, write the correct nominal displacement figures.

### Seals & Bearings

| Item | Name of Parts | Part Numbers |              |              | Qty. |
|------|---------------|--------------|--------------|--------------|------|
|      |               | PV2R14       | PV2R24       | PV2R34       |      |
| 11★  | Oil Seal      | ISD 45 68 12 | ISD 45 68 12 | ISD 45 68 12 | 1    |
| 12★  | O-Ring        | SO-NB-G145   | SO-NB-G145   | SO-NB-G145   | 1    |
| 13★  | O-Ring        | SO-NB-G80    | SO-NB-G105   | SO-NB-G135   | 1    |
| 14★  | O-Ring        | SO-NB-P28    | SO-NB-P28    | SO-NB-P28    | 1    |
| 15★  | O-Ring        | SO-NB-P22A   | SO-NB-P22A   | SO-NB-P22A   | 1    |
| 16★  | O-Ring        | SO-NA-G130   | SO-NA-G130   | SO-NA-G130   | 1    |
| 17★  | O-Ring        | SO-NA-G80    | SO-NA-G80    | SO-NA-G80    | 1    |
| 18★  | Back Up Ring  | SO-BE-G130   | SO-BE-G130   | SO-BE-G130   | 1    |
| 19★  | Back Up Ring  | SO-BB-G80    | SO-BB-G80    | SO-BB-G80    | 1    |
| 20★  | O-Ring        | SO-NB-G60    | SO-NB-G85    | SO-NB-G115   | 1    |
| 21★  | O-Ring        | SO-NB-G30    | SO-NB-P46    | SO-NB-A231   | 1    |
| 24   | Bearing       | 6209         | 6209         | 6209         | 1    |
| 25   | Bearing       | —            | —            | 6305         | 1    |

Note: 1) The o-rings and back up rings under item. Nos. ⑩ to ⑲ are included in the large volume pump cartridge kit and those under item. Nos. ⑳ and ㉑ in the small volume pump cartridge kit.

2) For pumps for phosphate ester type hydraulic fluids, different part Nos. are used. Please contact us.

★ When ordering seals, please specify the seal kit number from the table right.

### List of Seal Kits

| Pump Model Numbers    | Seal Kit Numbers |
|-----------------------|------------------|
| PV2R14-**-**-RAAA-32* | KS-PV2R14-30     |
| PV2R24-**-**-RAAA-31* | KS-PV2R24-30     |
| PV2R34-**-**-REAA-31* | KS-PV2R34-30     |